

NOTE: The ship specs and photos are available on the web site for the RV Brown:

<http://www.moc.noaa.gov/rb/index.html>

For other info/questions, please contact me at eric@al.noaa.gov or 303/497-3226

Measurements on NOAA/RV R.H. Brown for AIRMAP/2002 Study

<u>Species</u>	<u>Instrument</u>	<u>Spl/Data Freq</u>	<u>PI</u>
j-values	Spectral-radiometer: UV-VIS (custom instrument)	1 sec/1 min	R. Jakoubek
NO	NO-O3 chemiluminescence (custom instrument; DL: 10 pptv/1 sec)	1 sec/1 min	E. Williams
NO2	UV Photolysis/chemiluminescence (custom instrument; DL: 20 pptv/1 sec)	1 sec/1 min	E. Williams
NOy	Au tube/CO/chemiluminescence (custom instrument; DL (NO): 10 pptv/1 sec)	1 sec/1 min	E. Williams
NOy	Mo tube/chemiluminescence (custom instrument; DL (NO): 10 pptv/1 sec)	1 sec/1 min	E. Williams
PANs	GC/electron capture det./direct inject. (custom instrument: DL: 5 pptv/1 sec)	8 min (1 sec sample)	J. Roberts
Alkyl Nitrates	GC/electron capture det./cryo. trap (custom instrument; DL: ~0.1 pptv)	30 min (5 min. sample)	J. Roberts
Sfc. met.	WD/WS/Temp./H2O mix. rat./RH/Press. (commercial instrumentation)	1 sec/1 min	E. Williams

Measurements on NOAA/RV R.H. Brown for AIRMAP/2002 Study

<u>Species</u>	<u>Instrument</u>	<u>Spl/Data Freq</u>	<u>PI</u>
VOC	C2-C4: GC/flame ionization det./cryo. trap (custom instrument; DL: ~pptv)	30 min (5 min. sample)	W. Kuster
VOC	C4-C10 & oxygenates: GC/MS/cryo. trap (custom GC; HP MSD; DL: ~pptv)	30 min (5 min. sample)	P. Goldan
VOC	aromatics; oxygenates; nitriles: PTR-MS (custom instrument; DL: ~pptv)	1 sec/varies	J. deGouw
O3	NO-O3 chemiluminescence (custom instrument; DL: 4 pptv/1 sec)	1 sec/1 min	E. Williams
O3	UV absorbance (TEII 49c; no mods.; DL: 1-2 ppbv/10 sec)	10 sec/1 min	E. Williams
CO	GFC/IR spectrometry (TEII 48; modified; DL: ~50-60 ppbv/1 min)	1 sec/1 min	E. Williams
SO2	Pulsed UV fluorescence (TEII 43s; modified; DL: ~0.05 ppbv/1 min)	1 sec/1 min	E. Williams
CO2	IR absorbance/NDIR (LI-COR LI-7000; Resolution: <0.1 ppmv)	1 sec/1 min	E. Williams

Measurements on NOAA/RV R.H. Brown for AIRMAP/2002 Study

Species	Instrument	Spl/Data Freq	PI
Aerosol size	UDMPS/TSI: 3-22 nm	15 min/30 min	T. Bates
	DMPS/TSI: 22-900 nm	15 min/30 min	T. Bates
	APS/TSI: 0.6-9.6 um	15 min/30 min	T. Bates
Aerosol num.	CNC	15 min/30 min	T. Bates
Aerosol scatt.	TSI nephelometer	15 min/30 min	T. Bates
Aerosol absor.	Radiance PSAP	15 min/30 min	T. Bates
Aerosol size & composition	Aerosol Mass Spec.: nitrate; sulfate;org. (custom instrument; DL: 0.1 ug/m3)	1 sec/10 min	A. Middlebrook
Aerosol ionic composition	PILS/IC: nitrate, sulfate, chloride, ammon. (custom instrument; DL: 0.1 ug/m3)	7 min (4 min sample)	T. Bates
Aerosol size & composition	Impactor/IC/XRF/OC/EC (various instruments; possible 30 min OC/EC measurements)	4 hour sample	T. Bates

NOAA RV R.H. Brown
DECK 02
Sampling/Container Layout

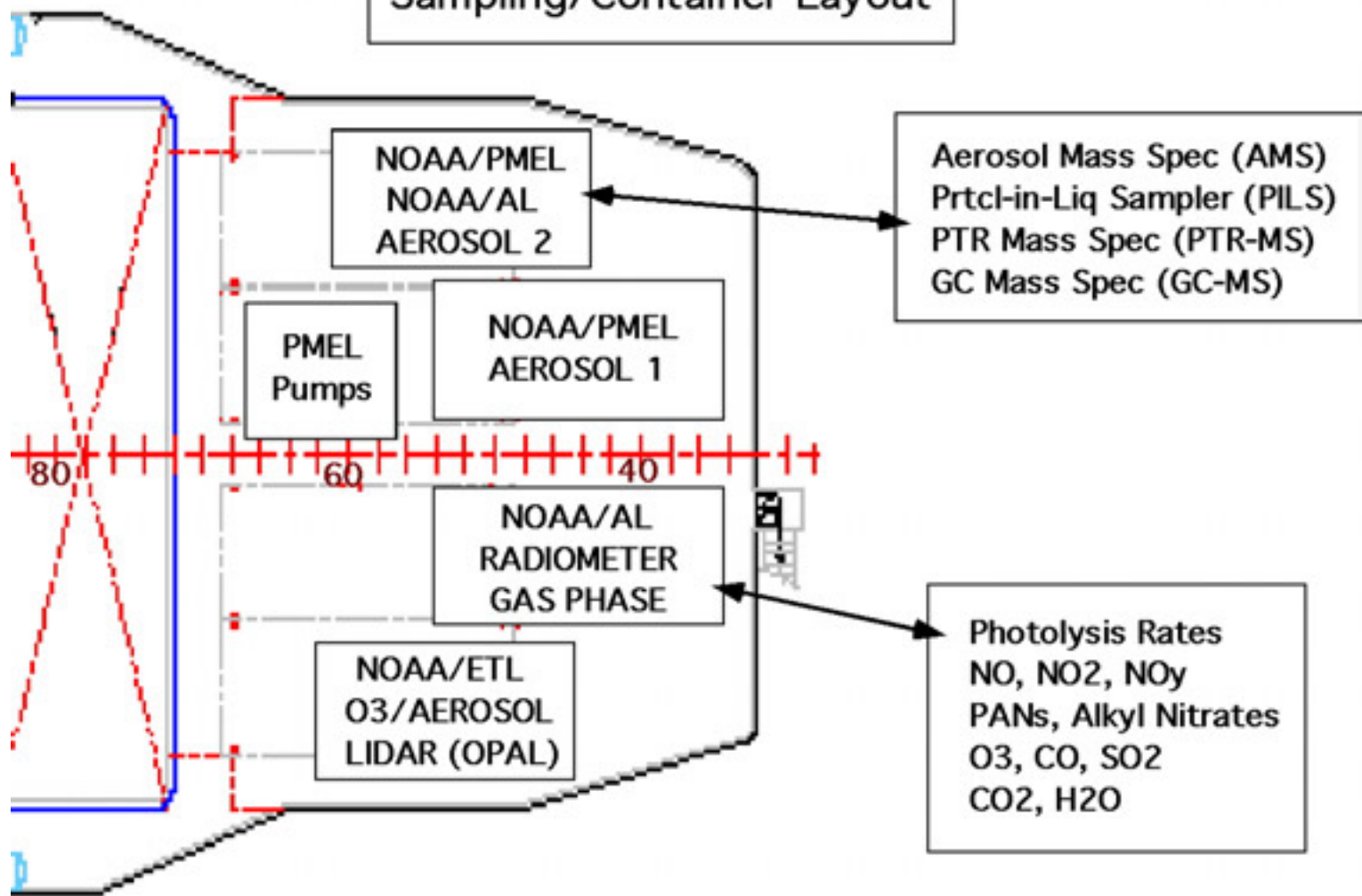

NOAA RV R.H. Brown
Sampling/Container Layout

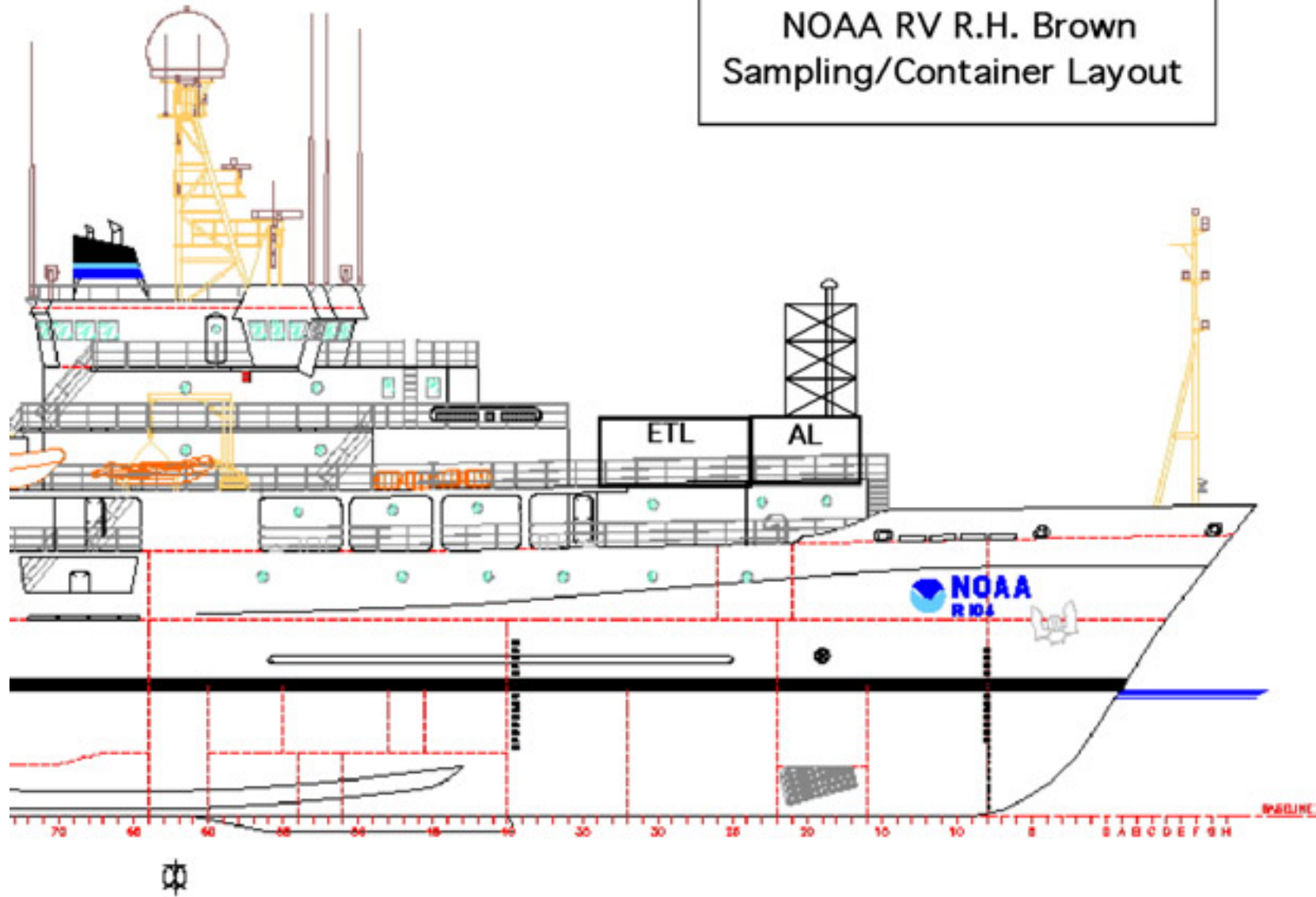

Proposed Ship Schedule

<u>Dates (2002)</u>	<u>Activity</u>
July 3	Containers to Charleston, SC
July 8-11	Load ship; connect/test instruments
July 12	Depart Charleston
July 12-26	Sampling: various cruise tracks
July 26-28	Portsmouth: docked for science team meetings, VIP tours, and public open house (UNH facility, Coast Guard base, ???)
July 26-Aug 10	Sampling: various cruise tracks
Aug 10	Arrive Charleston
August 10-12	Off-load containers